

MACHINING LIMITS TO
BE ± .10mm UNLESS
OTHERWISE STATED

ISSUE NO.	1	2	3	4	5	6	7	8
DATE	13 MAR 09	16 MAR 09	20 MAR 09	28 JUN 09	05 NOV 09	25 NOV 09	09 APR 10	08 OCT 10

THIRD ANGLE PROJECTION

ISSUE CONTROL NOTES:

- ISSUE 1 ORIGINAL
- ISSUE 2 SHEET NO CORRECTED TO 14
- ISSUE 3 DIFFUSER CHANNEL REMOVED
- ISSUE 4 PART NUMBERS ADDED
DISCHARGE VALVE REMOVED
- ISSUE 5 PRODUCT NAME CHANGED
DIRT TRAY CHANGED TO SIDE MOUNTING
- ISSUE 6 DIRT TRAY PART NOS CORRECTED
- ISSUE 7 CONTROL PANEL & WRINGER ROLLER ADDED
- ISSUE 8 PART NOS CORRECTED

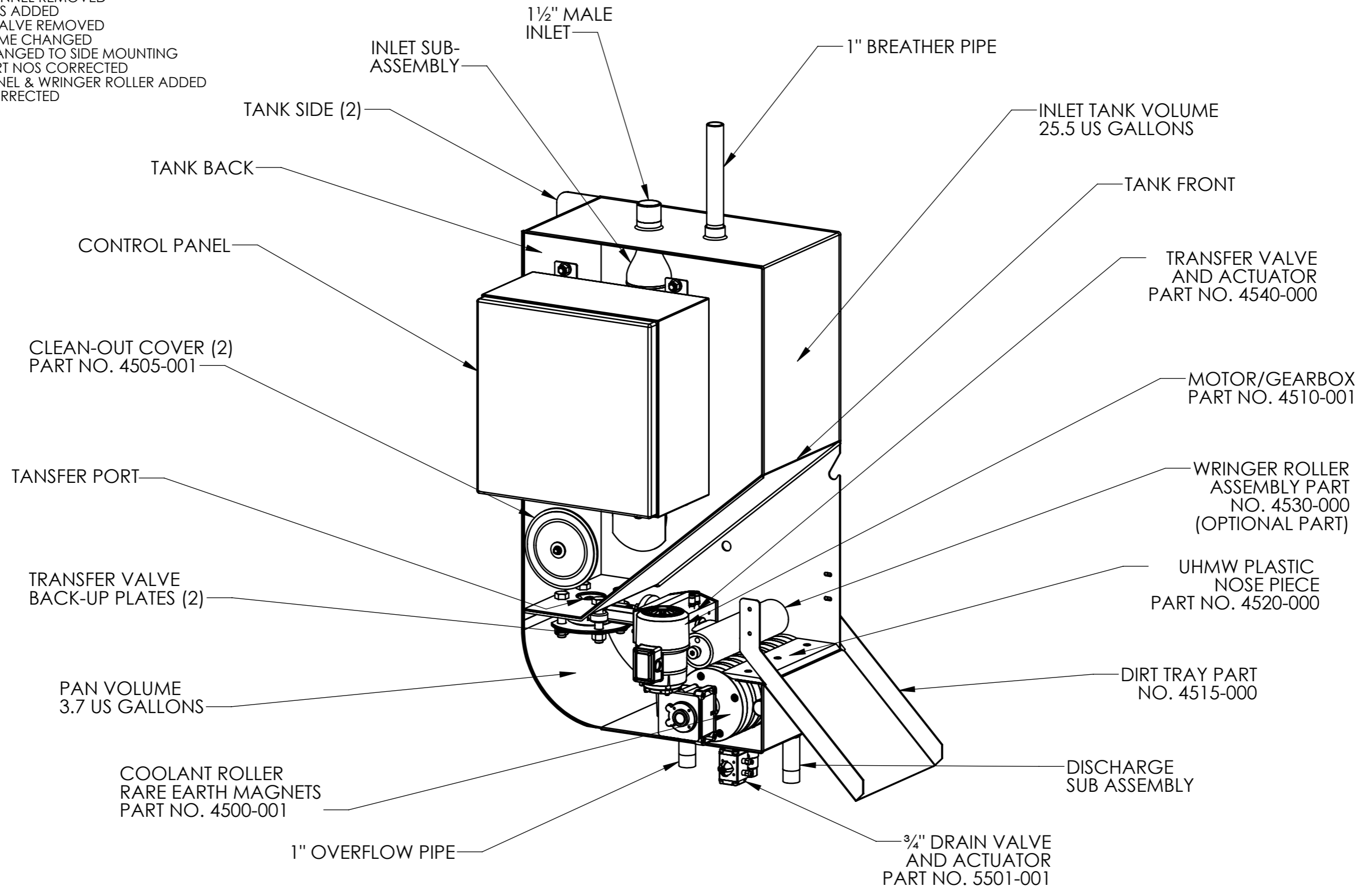

ALL DIMENSIONS ARE IN MILLIMETERS [INCHES]



TITLE
**SMART DRUM PLUS MAGNETIC SEPARATOR
PRINCIPAL COMPONENTS**

MATL: CARBON STEEL	DRAWN: WFSH
SPECN:	CHECKED: WFSH
No OFF:	DATE: 04 JUL 08

No 10330