

K FACTOR FILTER

LIQUID FILTRATION

MAGGIE

BY KFACTOR FILTER



Industrial Self Cleaning
Automatic Magnetic Filter

**“FILTERS DOWN
TO 1 MICRON!”**

HOW IT WORKS

1. Contaminated fluid enters Maggie from its top connection at system pressure.
2. The dirty fluid comes in contact with the thin walled, stainless steel tubes that contain powerful rare earth magnets.
3. The flow velocity inside is reduced, maximizing the contact time the particles are in contact with the magnetic field.
4. The combination of high-intensity magnets, low flow velocities, and a unique flow path will provide 80% better capture rates than conventional magnetic separators.
5. Once a sufficient quantity of debris is captured on the magnetic tube, an automatic purge is initiated. Using compressed air, the magnetic core is shuttled above the internal baffle plate. 100% of the captured solids are quickly released as the magnetic force has been removed.

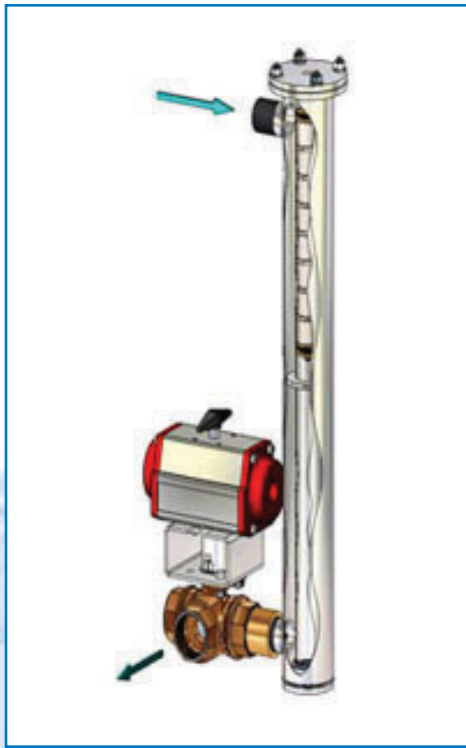

MAGNETIC CORE IN PURGE MODE



MAGNETIC CORE IN SEPARATION MODE

features & benefits

- Self -cleaning
- Fully automatic
- Fitted Inline
- Continuous operation
- Magnetic strength (10,000 Gauss)
- All stainless steel construction
- Flows from 12 GPM & up
- No maintenance
- Cost saving
- Easy installation
- No down time
- 15 times more powerful than conventional type
- Durability and long life
- Meets all flow requirements

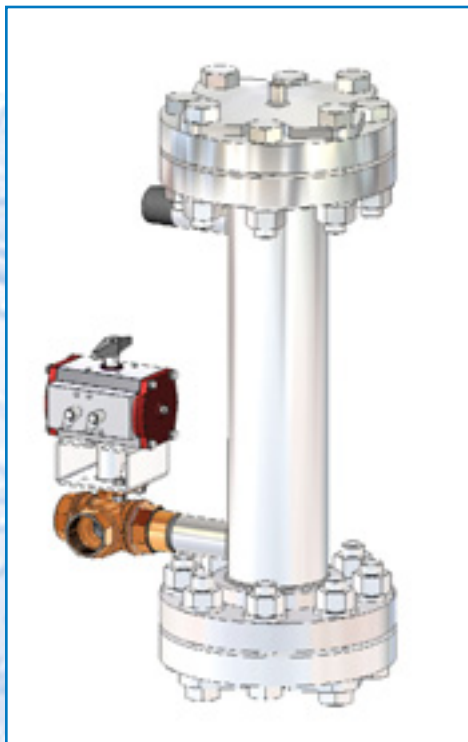

1 LB OF MAGNETIC DEBRIS MAX. PER PURGE



MAGGIE BY K FACTOR FILTER LIQUID FILTRATION

Specifications

FLOW <small>gpm</small>	MODEL	SIZE	INLET	OUTLET	VOLTAGE	PSI
12	K-MAG 12	2" SCH 10 S/S	3/4"	3/4"	110	60
35	K-MAG 35	3" SCH 10 S/S	1"	1"	110	80
75	K-MAG 75	5" SCH 10 S/S	1.5"	1.5"	110	80
125	K-MAG 125	8" SCH 10 S/S	2"	2"	110	80
250	K-MAG 250	10" SCH 10 S/S	3"	3"	110	80

SELF CLEANING AUTOMATIC MAGNETIC FILTER

ALL STAINLESS STEEL CONSTRUCTION
We will manifold to suit any flow requirements.



K-MAG MANIFOLD SYSTEM

APPLICATIONS

- AUTOMOTIVE
- GRINDING
- HONING
- MACHINING
- ENGINE WASHING
- PUMP PROTECTION
- MOTOR PROTECTION
- PARTS WASHING
- STEEL MILL WASH LINES
- SPRAY NOZZLE PROTECTION
- COOLANT RECOVERY

Tell us your filtration needs.

T. 905.420.8007 F. 905.420.7101

sales@kfactorfilter.com

www.kfactorfilter.com

